

8-Way RDM Enabled DMX Splitter



09.218SP.04294

Important: Read All Instructions Prior to Installation

Function introduction

Female 12-24VDC power connector (Requires male DC plug) DMX/RDM outputs 5-8: 3/5 Pin female XLR connector DMX/RDM input feed through: 3/5 Pin female XLR connector

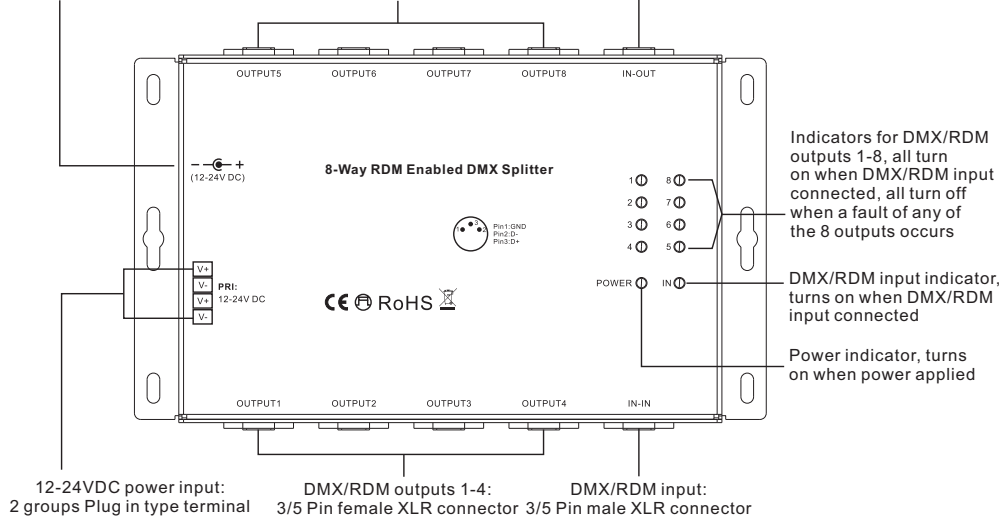

Product Data

No.	Input Voltage	Input Current	Input Signal	DMX/RDM Connection Ports	Connector Pin Out	Size(LxWxH)	Operation Temperature
1	12-24VDC	Max. 300mA	DMX/RDM	Input: (1x) Male 3-Pin XLR Output: (8x) Female 3-Pin XLR	Pin1: Ground Pin2: Data- Pin3: Data+	199x125x44mm	-20°C ~ +50°C
2	12-24VDC	Max. 300mA	DMX/RDM	Input: (1x) Male 5-Pin XLR Output: (8x) Female 5-Pin XLR	Pin1: Ground Pin2: Data- Pin3: Data+ Pin4: NC Pin5: NC	199x125x44mm	-20°C ~ +50°C

- 8-Way RDM enabled DMX splitter
- DMX/RDM compatible
- RDM enabled - ANSI E1.20 compliant
- Extend both cable distance (up to 300m) and the number of devices (up to 32 devices per output, total 256 devices)
- Plug and play, 3/5-Pin XLR male DMX input, eight XLR female DMX outputs
- 8 outputs are full isolated from the input, the outputs are not isolated from each other
- Each output provides LED data indicators, providing full confirmation of proper operation
- Supports bi-directional communications for discovery, addressing and DMX control of RDM enabled devices
- A feed through XLR female connector is provided at the input, allowing this unit to be placed in the middle of an existing DMX chain

Safety & Warnings

- DO NOT install with power applied to device.
- DO NOT expose the device to moisture.

Wiring Diagram

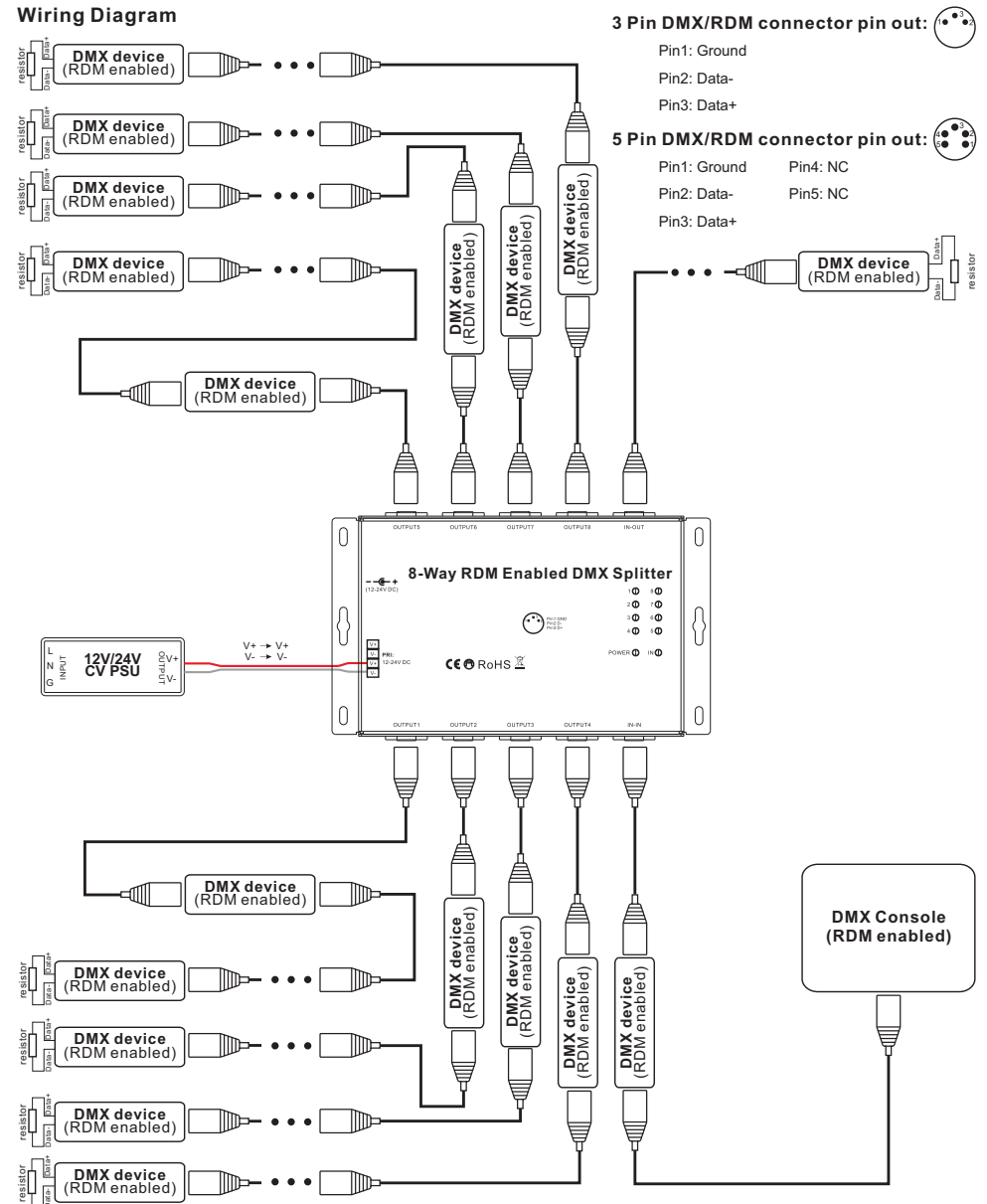

Note:

- 1) This splitter is placed in the middle of an existing DMX chain.
- 2) Max. allowed data cable length in a DMX chain is 300m, each output is branch DMX chain.
- 3) Max. allowed data cable length connected to each output (branch DMX chain) is 300m.
- 4) Max. 32 devices can be connected to each output of the splitter in daisy-chain.
- 5) Total 32*8=256 devices can be connected to 8 outputs of the splitter.
- 6) Please attach a 120ohm, 0.5W resistor between Data+ and Data- wires on the last device of each DMX chain.

Product Dimension

